

ACRYLIC SHOWER WALL INSTALLATION GUIDE

As per requirements of the Building Code of Australia and AS3740-2010, ensure the area is fully waterproofed before installing the shower wall.

1. Place the shower wall panels in desired position to check that it fits correctly. Pencil around the edges to use as a guide. Mark and drill the holes for the tap fittings using a fine-tooth hole saw allowing at least 2mm clearance.

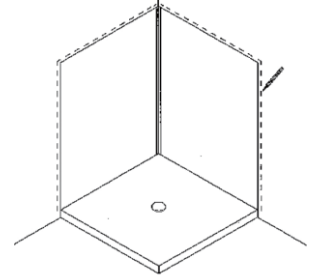

2. Run a bead of anti-fungal wet area silicone sealant along the length of the plastic internal corner channel. Only apply silicone to one side for now.

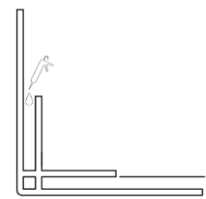

Internal Corner Channel

Panel Assembly

3. Peel back the protective film on the wall panel just enough to allow the panel to slot into the plastic internal corner channel.

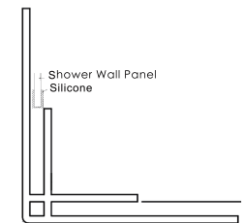

Internal Corner Channel

Installing Wall Panel

4. Using the pencil marks as a guide, apply a non-silicone based adhesive (we recommend Sika Showerbond - available at Bunnings) in continuous vertical lines onto the wetboard 100mm apart at least 15mm from the edges. Allow 15mm clearance for tap fittings.

DO NOT APPLY ANY ADHESIVE ALONG THE TOP EDGES. This can cause the shower wall to warp and buckle due to the trapped air expanding.

5. Run a continuous bead of silicone onto the wetboard vertically, the entire height of the panel, 10mm from the corner (on both sides).

Place the shower wall panel in position ensuring that the plastic internal corner channel is pressed against the silicone first. The bottom edge of the wall panel should be sitting against the shower base.

Expel air pockets by pushing air out of the top end of the panel. Immediately clean away any excess silicone or adhesive.

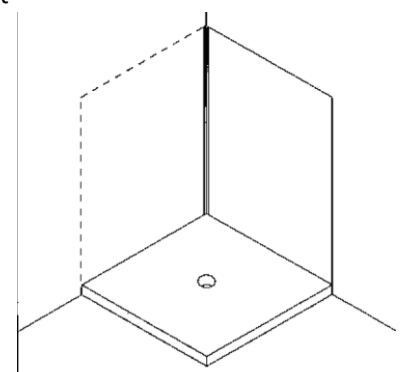
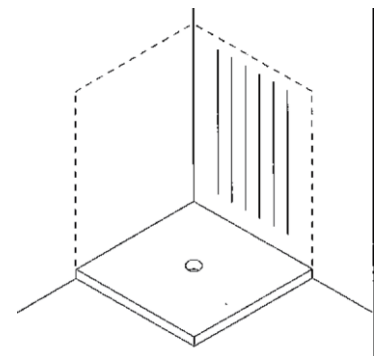

6. Apply the adhesive for the second panel in the same way as step 4.

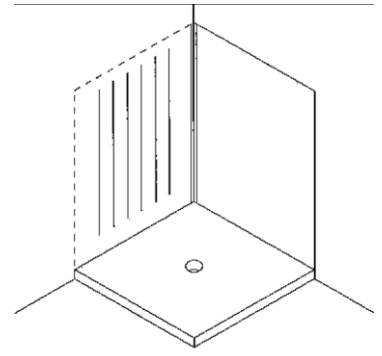

7. Run a bead of silicone along the length of the plastic internal corner channel for the second panel.

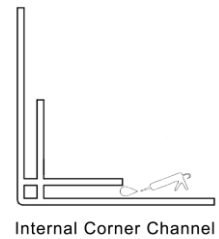

8. Peel back the protective film on the second panel just enough to allow it to slot into the plastic internal corner channel. Starting from the bottom, start fitting the panel into the plastic internal corner channel ensuring the panel is fully seated.

Check the positioning of the shower wall panels and adjust if necessary. Once satisfied with the position, go over the entire shower wall panels pressing it against the wetboard to ensure full contact is achieved. Expel air pockets by pushing air out of the top end of the panel. Immediately clean away any excess silicone or adhesive.

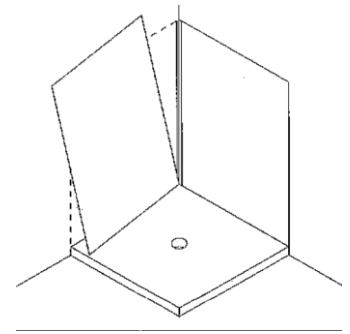

The shower wall panels should be braced as required and should remain for 24 hours for complete curing.

9. Once the adhesive is fully cured, remove the remaining protective film from the shower wall panels. Apply silicone sealant along the sides of the shower wall panels, as well as around the holes for the tap fittings.

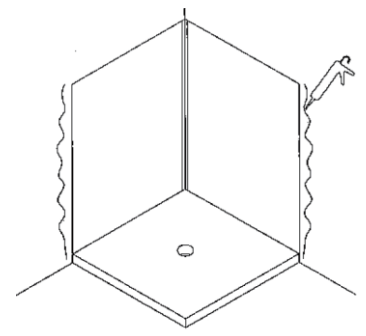

10. Apply silicone sealant to where the shower wall panel meets the shower base. Allow sealant to fully cure (refer to sealant instructions) before using the shower.

