

# Weight loading and spanning guide

Connect-it is a light duty system for use around the home or office. It can also be used for retail displays and vehicle shelving/racking solutions it is not intended as a heavy duty system. As a guide, the longer the span between the vertical uprights, the lighter the load needs to be.

Below is a graph showing approximate acceptable loads and maximum spans. Please note these figures refer to supported spans only, i.e. they are cube like designs\*. Horizontal spans must be supported and not just reliant on the joiner.

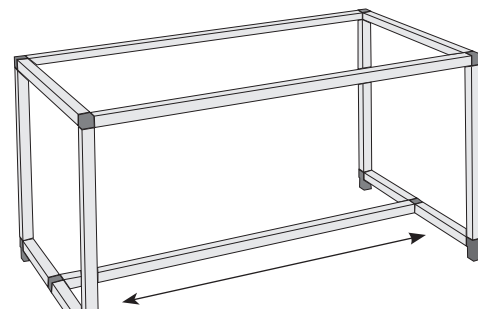
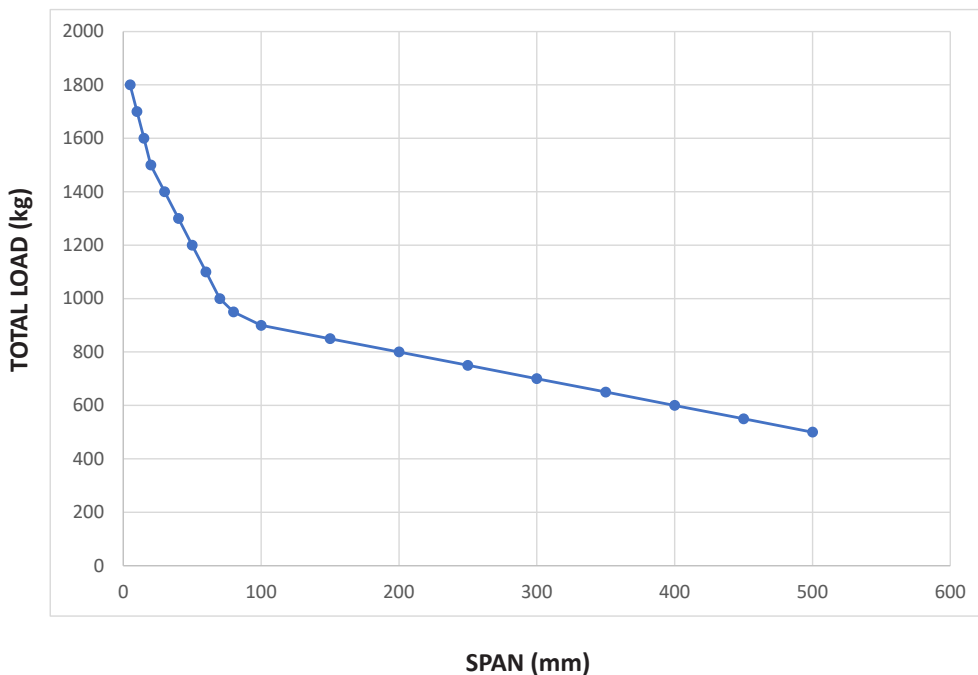

Handy hint: We have used a 3 way flat joiner rather than a 2 way joiner to create feet, raising the table legs off the floor.

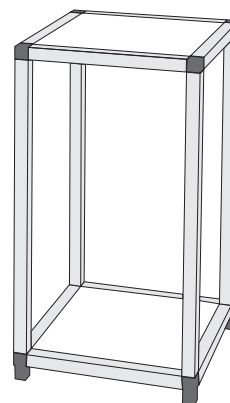

\*Cube like designs where the legs are supported are much stronger.

## How to build using the Connect-it range

- Lay out all your lengths and joiners for your project ensuring everything is at hand.
- Place things out so you have an idea of what order they will need to be assembled in.
- If using a lipped profile for shelf or glass table tops make sure the lip is positioned correctly.
- Assemble the vertical lengths first using the joiners.
- Stand lengths beside each other and check that all the joiners are positioned correctly and will accept the horizontal lengths.
- For a neater and more professional looking finish; take care if you need to cut any of the lengths.
- Clamping securely will assist in making more accurate and squarer cuts. After cutting, deburr or file clean and square up the ends.
- Do not finally tap together profiles to joiners until you are sure of everything.
- Once joiners are tapped home they are very difficult to remove.
- With shelves allow a little wiggle room so they are not too tight.
- When you are confident everything fits how you intended then gently tap the joiners into place.
- Use a rubber mallet or a block of some sort to protect the tube from damage.

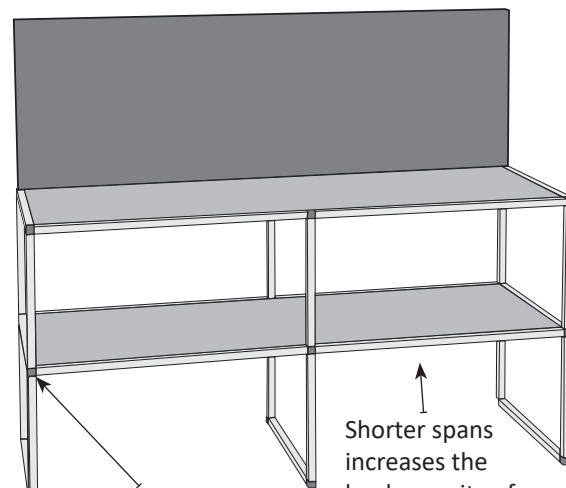

Longer legs could have a joiner at the cross member with supported legs at the bottom or a combination of both.

*"Information is intended as a guide only and being up to the end user to determine the suitability or not of the product for their project".*

## Corners

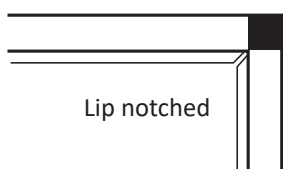

Lip notched

OR

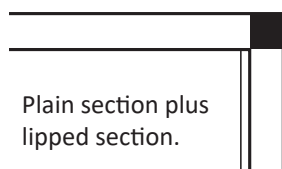

Plain section plus lipped section.

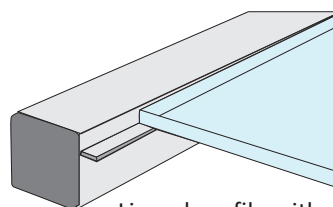

Lipped profile with glass shelf.

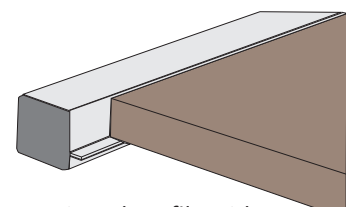

Lipped profile with timber shelf

# How to create a 4 shelf display unit



**Dimensions:**  
1350mm high x  
1200mm width x  
450mm deep

## What you will need:

### Shelf:

8 lengths x 1200mm lipped tube  
8 lengths x 450mm plain tube

### Uprights:

12 x 450mm plain tube

### Plastic Connectors:

8 x 3 way corner connectors  
8 x 4 way corner connectors

### Shelves:

4 x 1200mm x 450mm - 16mm MDF board, glass or whatever material you choose for your shelves.

Lipped tube to hold shelves securely.

3 way used, alternatively use a 4 way to raise it off the floor.

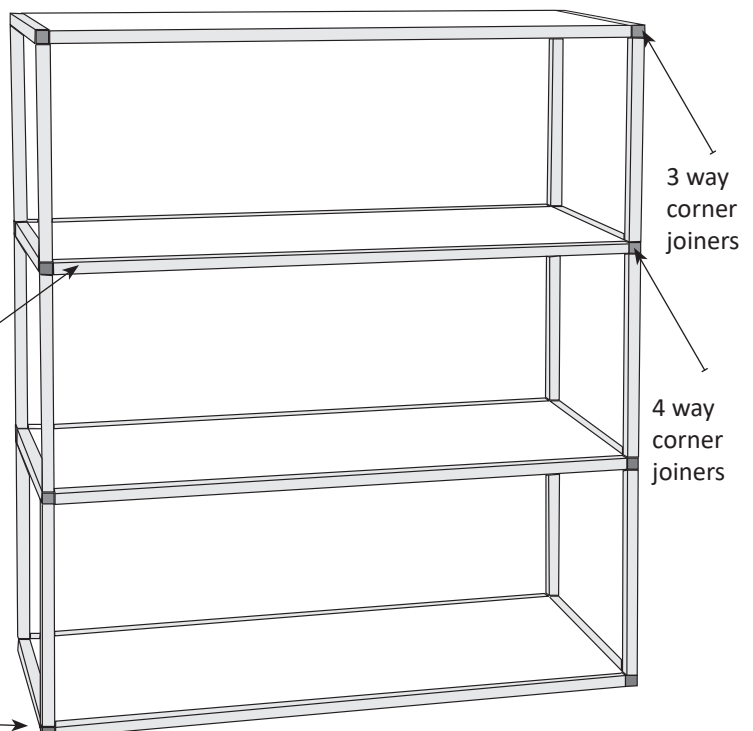

**RCR International Pty Ltd**

PO Box 148, Braeside VIC 3195 Tel: (03) 9558 2020 Fax: (03) 9558 3030  
Email: [service@rcr.com.au](mailto:service@rcr.com.au) [www.rcr.com.au](http://www.rcr.com.au) ABN 21 089 270 360

Aug 2021