

ozito

MITRE SAW STAND

2050mm

INSTRUCTION MANUAL

SPECIFICATIONS

Width (extended):	2050mm
Width (not extended):	1055mm
Height:	820mm
Roller Size:	230mm
Weight Capacity:	150kg
Weight:	13.4kgs

ozito.com.au

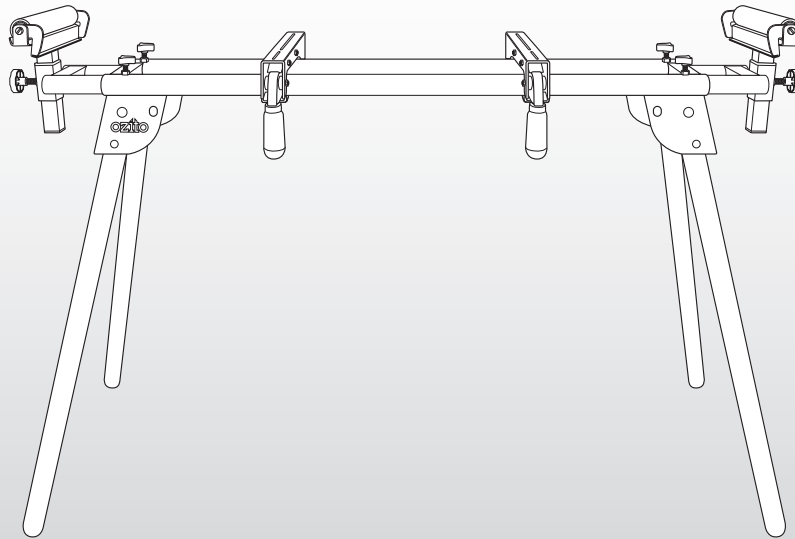

WHAT'S IN THE BOX



Mitre Saw Stand

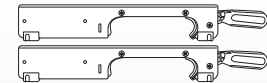

Mitre Saw Mount
Brackets x 2

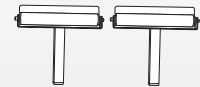

Work Supports x 2



Height Adjustment
Knobs x 2

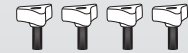

Length Adjustment
Knobs x 4



Fixing Bolts, Nuts
& Washers x 4

3 YEAR REPLACEMENT WARRANTY

MSS-003

KNOW YOUR PRODUCT

MITRE SAW STAND

1. Support roller locking knobs
2. Work support roller
3. Mitre saw mounts
4. Mitre saw rail tubes
5. Extension bar locking knobs
6. Extension bars
7. Material stop
8. Leg release buttons
9. Leg support
10. Mitre saw mount handle
11. Foldable leg

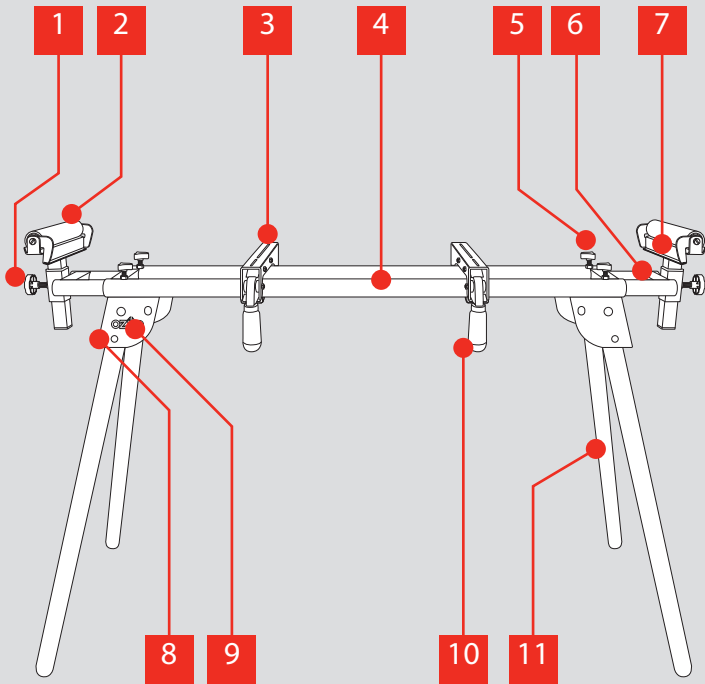

ACCESSORIES

12. Mitre saw fixing bolts, nuts and washers

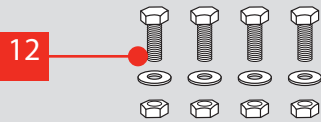

ONLINE MANUAL

Scan this QR Code with your mobile device to take you to the online manual.



SETUP & PREPARATION

1. ASSEMBLY

Leg assembly

Note: This process may be easier with the assistance of another person.

1. Remove the Mitre Saw Stand from the packaging.

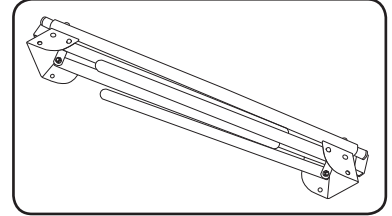

2. Carefully tilt the mitre saw rail tubes to one side so you can see the foldable legs underneath.

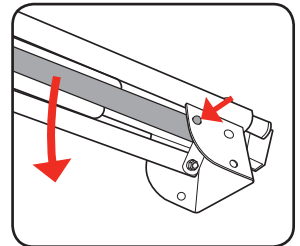

3. Whilst holding the mitre saw rail tubes, push in the leg release button and extend a foldable leg all the way out so that the leg release button locks into the outside holes of the leg support.

4. Repeat for all four foldable legs.

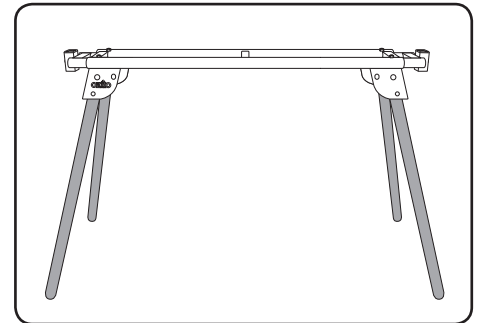

5. When all four foldable legs have been secured in position, turn the Mitre Saw Stand the correct way up and ensure all the foldable legs are properly secured.

3 YEAR REPLACEMENT WARRANTY

Fitting the extension bar locking knobs

Fit two extension bar locking knobs to each end of the Mitre Saw Stand and secure to lock the extension bar into position.

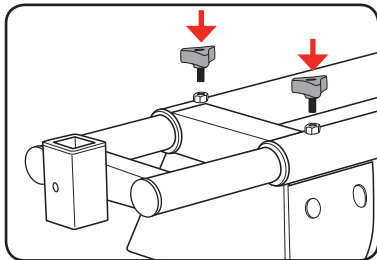

Fitting the work support rollers

1. Fit a work support roller into the fixing hole at one end of the Mitre Saw Stand (ensure that the material stops are facing inwards).

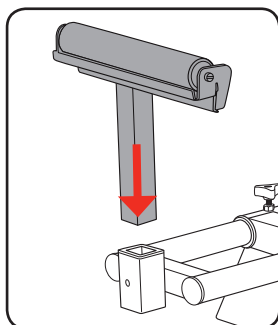

2. Secure the work support roller by inserting and tightening the support roller locking knob by turning clockwise.

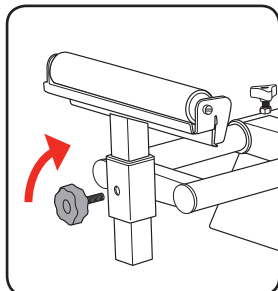

3. Repeat for the opposite side.

Fixing the mitre saw mounts

1. Place the mitre saw mounts on top of the mitre saw rail tubes, ensure that the mitre saw mount handles are positioned at the front of the mitre saw rail tubes.

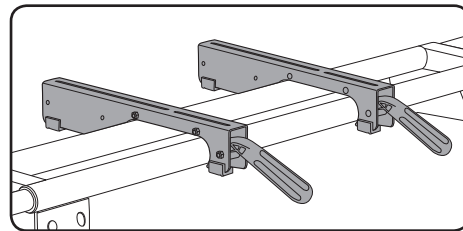

2. Secure the mitre saw mounts by pushing down the mitre saw mount handle to lock them in position.

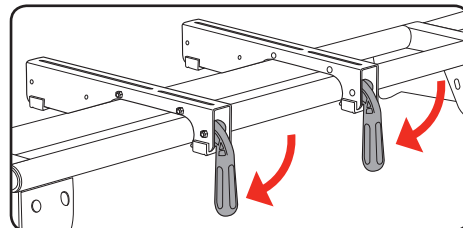

2. ADJUSTMENTS

Adjusting the extension bars

1. Loosen the two extension bar lock knobs.

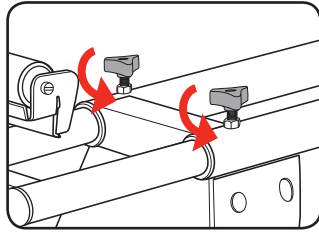

2. Extend the extension bar to the required distance in order to properly support the workpiece.

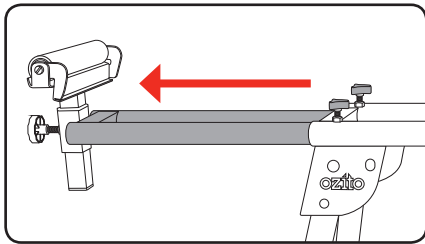

3. Tighten the two extension bar locking knobs.

4. Repeat for the opposite side as required.

Adjusting the work support rollers

1. Loosen the support roller locking knob.

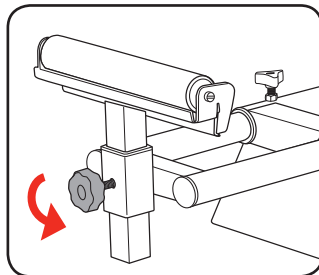

2. Adjust the height of the work support roller as required to support the workpiece.

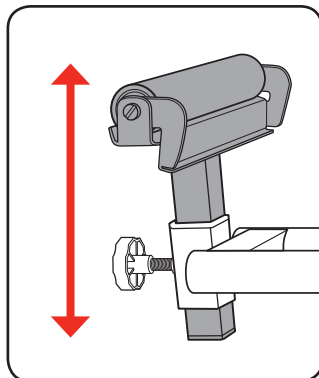

3. Tighten the support roller locking knob to secure the work support roller in position.

Material stops

1. The Mitre Saw Stand features material stops which allow repetitive cuts to be made quickly and accurately.

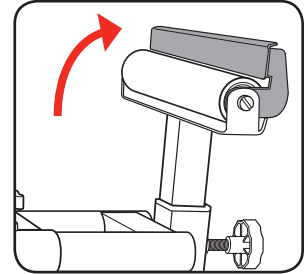

2. Lift the material stop so it is in the raised position.

3. Adjust the extension bars until they correspond to the desired cutting length.

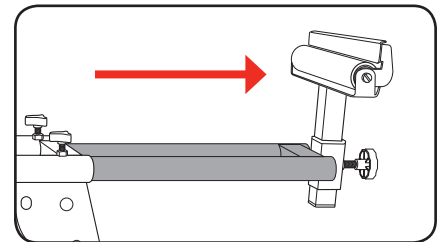

4. Place the end of the workpiece against the material stop and commence the cut.

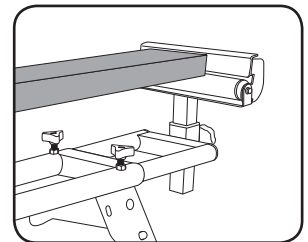

OPERATION cont.

Attaching a mitre saw

Your mitre saw should have four fixing holes, one hole in each corner of the base. If the mitre saw does not have four holes, do not place it on this Mitre Saw Stand as it cannot be properly secured.

1. Adjust the mitre saw mounts roughly to the width of the mitre saw base.

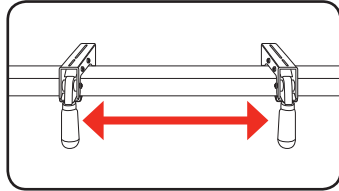

2. Place the mitre saw on the mitre saw mounts and line up the holes in the mitre saw base with the grooves in the mitre saw mounts.

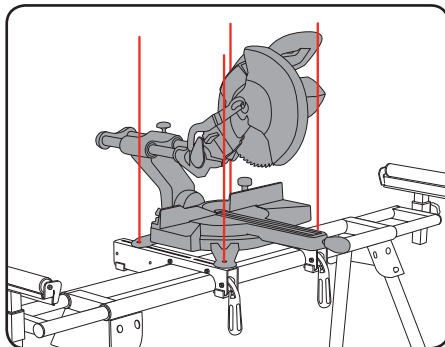

3. Feed a bolt through the bottom of the mitre saw mount followed by the base of your mitre saw.

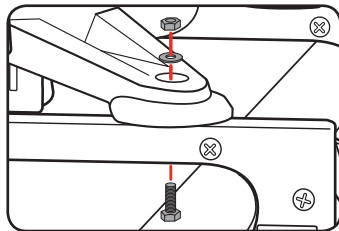

4. Fit a flat washer over the bolt and secure using a nut.

5. Repeat steps 1-3 for the remaining three holes in the mitre saw using the remaining bolts, nuts and washers.

Note: During operation and before starting a new job, ensure that all screws and nuts are tightened correctly and securely.

MAINTENANCE

3. GENERAL MAINTENANCE

Cleaning

Wipe away dirt and dust from the Mitre Saw Stand on a regular basis.

Storage and transport

1. The Mitre Saw Stand can be easily folded for convenient storage and transportation.

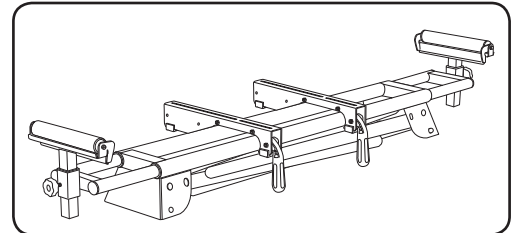

2. Simply follow the leg assembly instructions in reverse to fold up the Mitre Saw Stand.

Note: When transporting the Mitre Saw Stand in a vehicle, always tie it down to prevent movement and possible damage.

Note: Ozito Industries will not be responsible for any damage or injuries caused by the repair of the tool by an unauthorised person or by mishandling of the Mitre Saw Stand.

GENERAL SAFETY WARNINGS

1. **Keep work areas clean.** Cluttered work areas can cause accidents.
2. **Consider work area environment.** Keep the work area well lit.
3. **Keep children away.** Do not allow children, visitors or animals to come near the work area.
4. **Do not overreach.** Keep proper footing and balance at all times.
5. **Stay alert.** Watch what you are doing. Use common sense. Do not operate a saw mounted to the stand when you are tired.
6. **Users.** This appliance is not intended for use by young children or infirmed persons without supervision. Young children should be supervised to ensure that they do not play with this appliance.

ADDITIONAL SAFETY INSTRUCTIONS FOR MITRE SAW STANDS

- Always ensure the mitre saw base is properly secured to the stand prior to operation.
- Always ensure the stand legs have been locked into place prior to operation.
- Take care when moving the stand especially when a mitre saw is mounted.
- Do not use the stand for any other purpose than what it is intended for.
- Do not use the stand as a stepping stool or ladder.
- Make sure all moving parts are free from interference.
- Keep hands clear of all moving parts.
- Ensure the Mitre Saw Stand is set up on firm ground in a stable manner.
- Use the Mitre Saw Stand in a dry place protected from the rain.
- Be aware of overbalancing. When a large piece is cut from one end of a job, the remaining piece may be heavy enough to over-balance the Mitre Saw Stand. Always ensure the workpiece is well supported.
- When transporting the Mitre Saw Stand in a vehicle, always tie it down to prevent movement and possible damage.
- Check to make sure that all fixing screws and knobs are tight and all legs are locked into position before operation.
- The Mitre Saw Stand must be used only for its prescribed purpose. Any use other than those mentioned in these instructions will be considered a case of misuse.
- Ozito Industries shall not be liable for any damage or injury resulting from such cases of misuse.
- Ozito Industries shall not be liable for any changes made to the Mitre Saw Stand nor for any damage resulting from such changes.

CARING FOR THE ENVIRONMENT



Tools that are no longer usable should not be disposed of with household waste but in an environmentally friendly way. Please recycle where facilities exist. Check with your local council authority for recycling advice.



Recycling packaging reduces the need for landfill and raw materials. Reuse of recycled material decreases pollution in the environment. Please recycle packaging where facilities exist. Check with your local council authority for recycling advice.

SPARE PARTS

Limited spare parts are available subject to availability. Please contact your local Bunnings Special Orders Desk to order the required spare parts.

Most common spare parts listed below

Spare Part	Part No.
Star knob (pack of 2)	SPMSS003-07
Knob (pack of 2)	SPMSS003-12
Mitre Saw Mounts	SPMSS003-25A

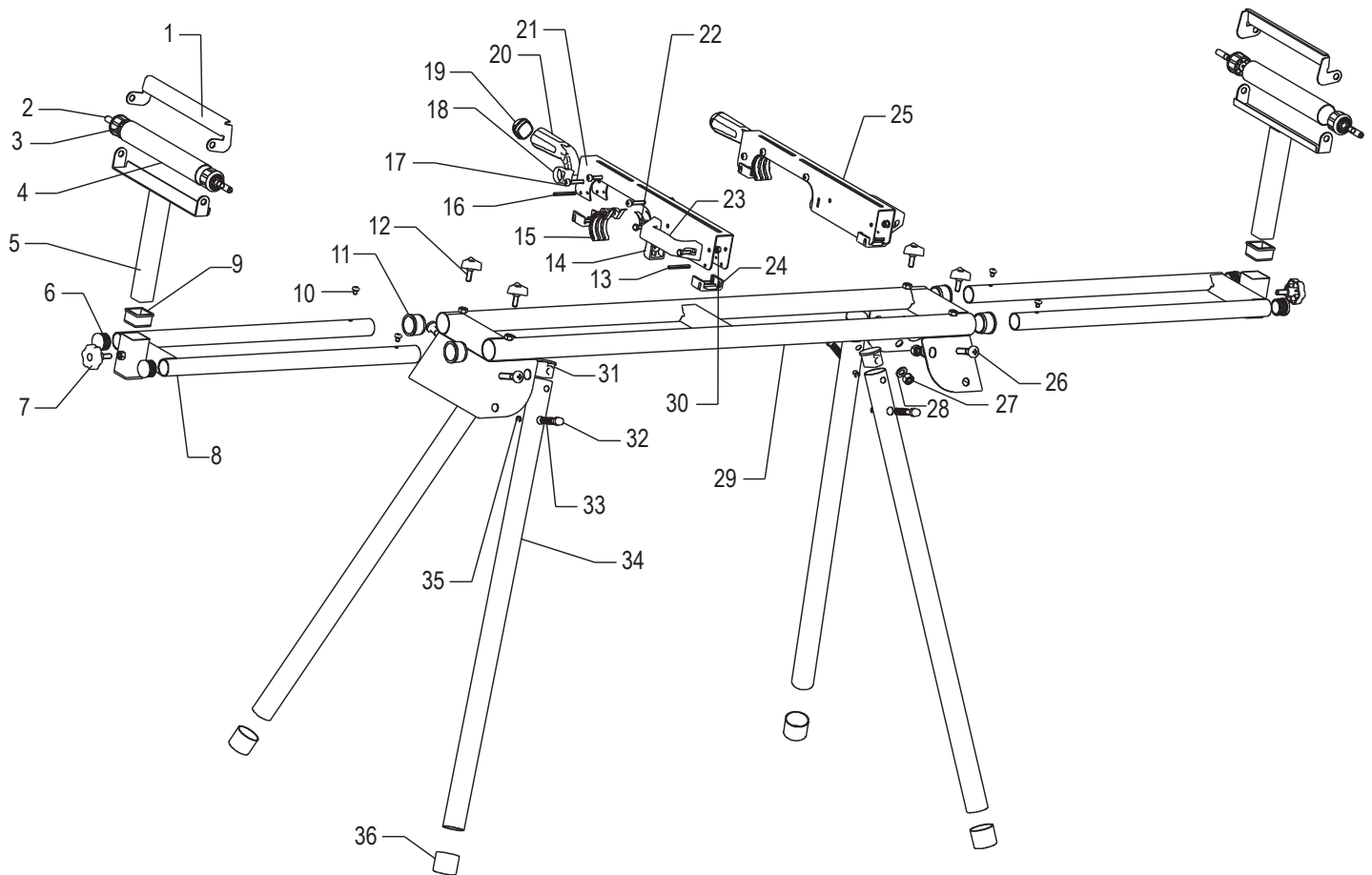

The following is a list of spare parts carried by Ozito. Please contact Customer Service for any parts not listed.

Item No.	Description	Part No.	Item No.	Description	Part No.
07	Star Knob (pack of 2)	SPMSS003-07			
12	Knob (pack of 2)	SPMSS003-12			
25	Mitre Saw Mounts	SPMSS003-25A			

How To Order

Available spare parts can be ordered through the Special Orders Desk at any Bunnings Warehouse. If you have any further questions, please contact Ozito Customer Service on:

Australia: 1800 069 486

New Zealand: 0508 069 486

enquiries@ozito.com.au

WARRANTY

IN ORDER TO MAKE A CLAIM UNDER THIS WARRANTY YOU MUST RETURN THE PRODUCT TO YOUR NEAREST BUNNINGS WAREHOUSE WITH YOUR BUNNINGS REGISTER RECEIPT. PRIOR TO RETURNING YOUR PRODUCT FOR WARRANTY PLEASE TELEPHONE OUR CUSTOMER SERVICE HELPLINE:

Australia 1800 069 486

New Zealand 0508 069 486

TO ENSURE A SPEEDY RESPONSE PLEASE HAVE THE MODEL NUMBER AND DATE OF PURCHASE AVAILABLE. A CUSTOMER SERVICE REPRESENTATIVE WILL TAKE YOUR CALL AND ANSWER ANY QUESTIONS YOU MAY HAVE RELATING TO THE WARRANTY POLICY OR PROCEDURE.

The benefits provided under this warranty are in addition to other rights and remedies which are available to you at law.

Our goods come with guarantees that cannot be excluded at law. You are entitled to a replacement or refund for a major failure and for compensation for any other reasonably foreseeable loss or damage. You are also entitled to have the goods repaired or replaced if the goods fail to be of acceptable quality and the failure does not amount to a major failure.

Generally you will be responsible for all costs associated with a claim under this warranty, however, where you have suffered any additional direct loss as a result of a defective product you may be able to claim such expenses by contacting our customer service helpline above.

3 YEAR REPLACEMENT WARRANTY

Your product is guaranteed for a period of 36 months from the original date of purchase. If a product is defective it will be replaced in accordance with the terms of this warranty. Warranty excludes consumable parts, for example: adjustment knobs, brackets, work supports, bolts, nuts and washers.

The following actions will result in the warranty being void.

- ï If the tool shows signs of damage or defects caused by or resulting from abuse, accidents or alterations.
- ï If the tool is disassembled or tampered with in any way.
- ï Professional, industrial or high frequency use.