

jumbuck®

MONTH
12
WARRANTY









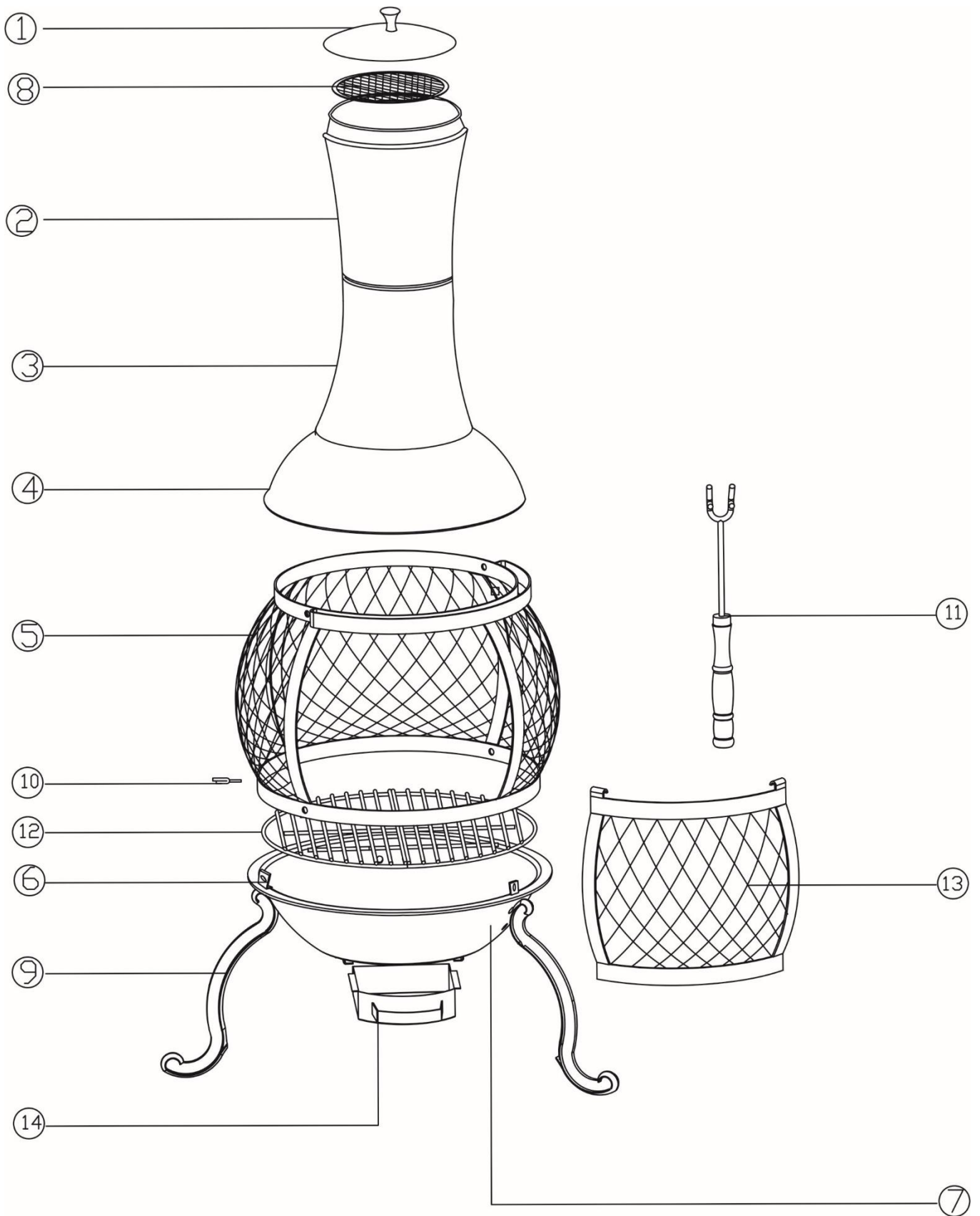



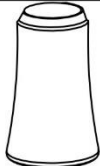

Chimineia And Stand

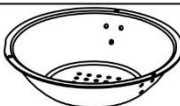

- Powder coated steel body & mesh
- Fire poker included
- For outdoor use only
- Easy assembly
- 15H cm including stand
- Chimenea dimensions: 53Dx145Hcm



jumbuck®



NO.	Picture	Part name	Q' TY
1		CAP	1
2		UPPER FLUE	1
3		LOWER FLUE	1
4		STOVE TOP	1
5		MESH STOVE ASSEMBLY	1
6		CONNECT PLATE-3	3
7		STOVE BOTTOM	1
8		SPARK ARRESTOR SCREEN	1
9		LEG 3	3
10		HOOK	1
11		FIRE POKER	1
12		GRATE-2	2
13		DOOR	1
14		ASH TRAY	1

A		BOLT M6X20mm	9
B		BOLT M6x25mm	15
C		NUT M6	25



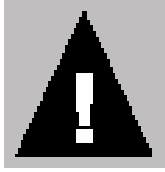

- ⚠ **For outdoor use only.**
- ⚠ **Improper installation, adjustment, alteration, service or maintenance can cause property damage, injury or death. Read the installation, operating and maintenance instructions thoroughly before installing or servicing this equipment.**
- ⚠ **Warning: accessible parts may be very hot. Keep young children away.**
- ⚠ **Do not move the appliance during use.**
- ⚠ **Any modification of the appliance may be dangerous.**
- ⚠ **Installer to leave instructions with the consumer and consumer to retain them for future reference.**



Dispose of all polythene packaging carefully and keep out of the reach of children. Please read the section on Important Notes prior to using your Chiminea.

TOOLS REQUIRED

- *Philips screwdriver
- *Pliers or adjustable spanner

IMPORTANT NOTES

- *Do not use this chiminea indoors.
- *Do not use this chiminea inside a tent, gazebo or within a confined space.
- *This chiminea will become very hot during use and for some time after use. Keep children away from the chiminea and do not touch metal parts of the chiminea when in use. Use suitable gloves for protection, especially when loading the chiminea with logs or coal. We recommend protecting your chiminea when not in use with a cover to protect from rusting and exposure to rain.

STEP 1

Place stove bottom (7) on its side and attach three legs (9) using nine bolt M6X25mm and nuts. Tighten securely.

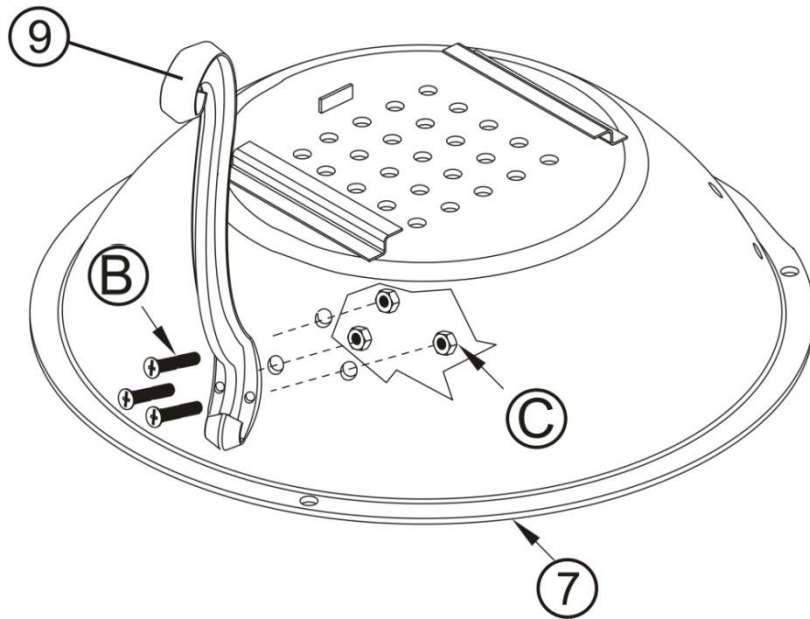

STEP 2

Insert two Grates (12) in the Stove Bottom (7). Attach three Connector plates-3 (6) to stove bottom (7) using three Bolt M6X20mm and Nuts. Leave loosely tightened

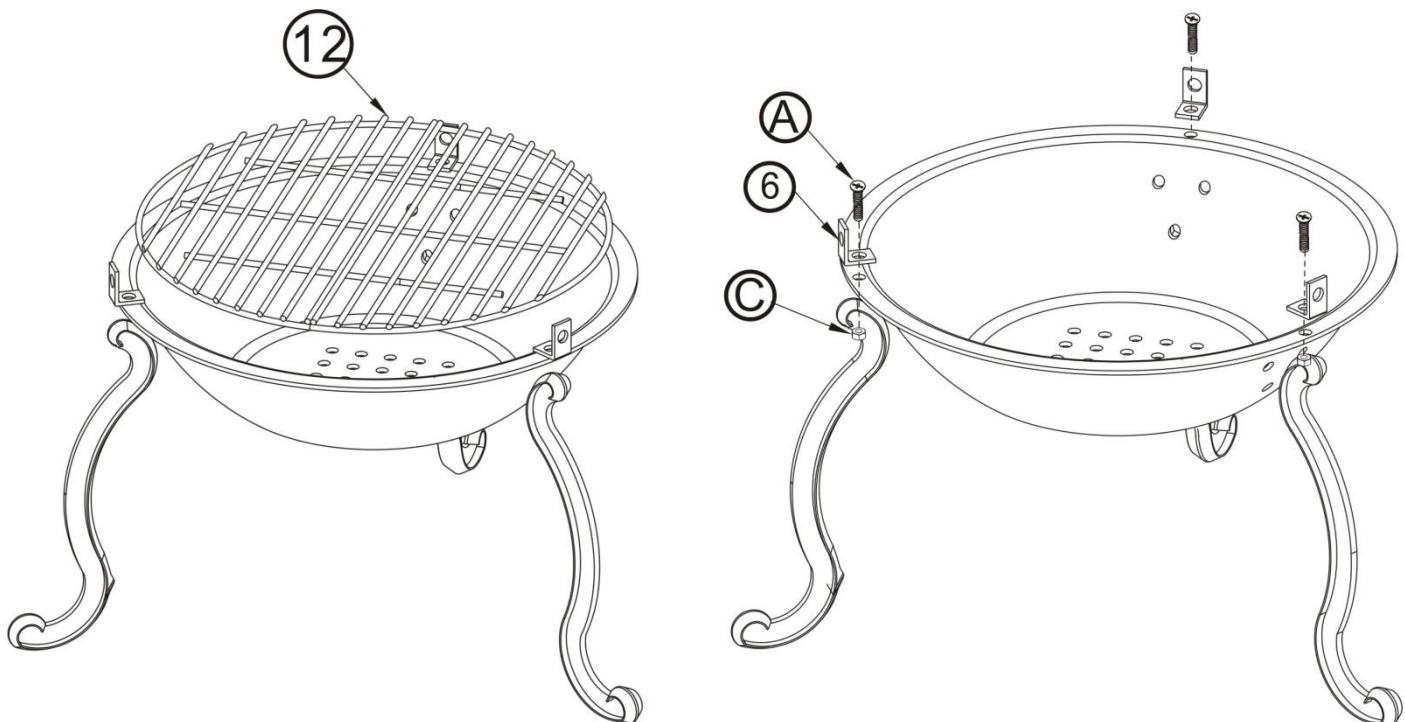

STEP 3



Attach the Hook (10) on left side of the mesh stove assembly (5) using a nut.

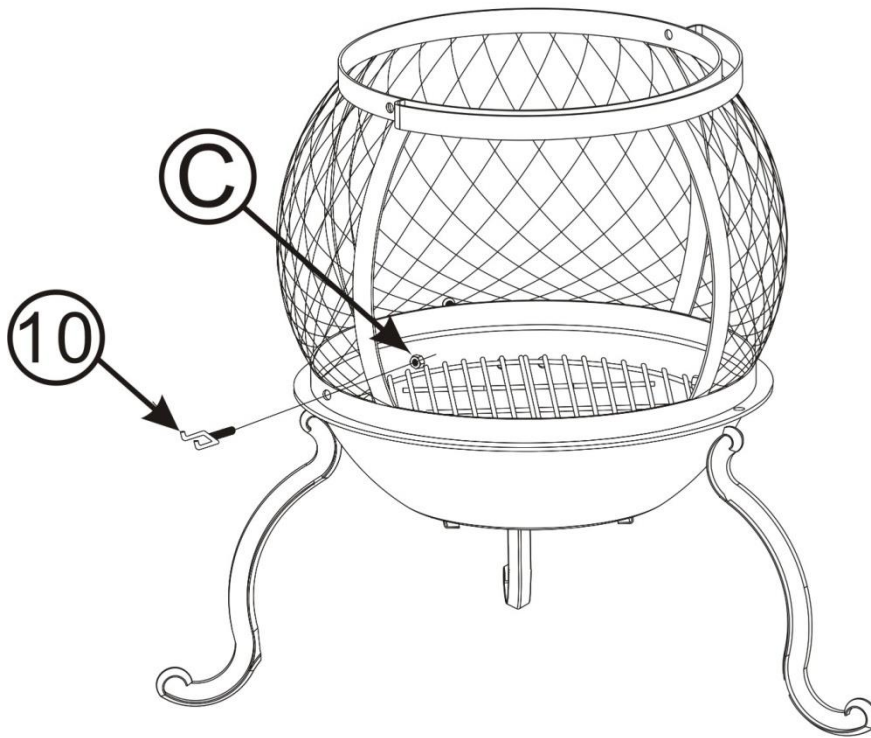

STEP 4

Install Mesh Stove Assembly (5) on Stove Bottom assembly from previous steps. Align connector plates and fasten using three Bolt M6X20mm and Nuts.

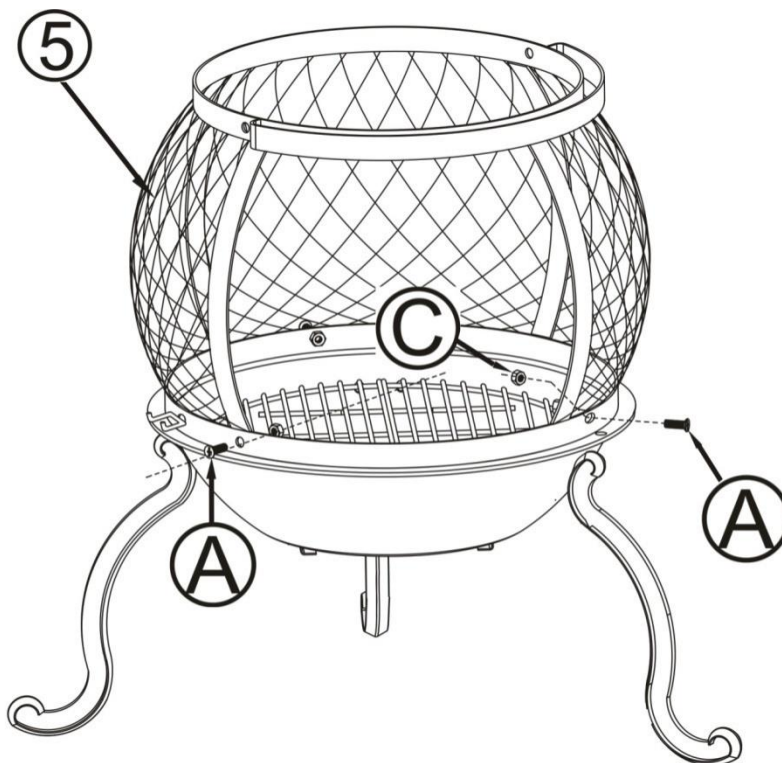

STEP 5

Install stove top (4) on mesh stove assembly (5) . Align the holes on the top with the holes in the connector plates and connect using three Bolt M6X25mm and Nuts. Leave loosely tightened.

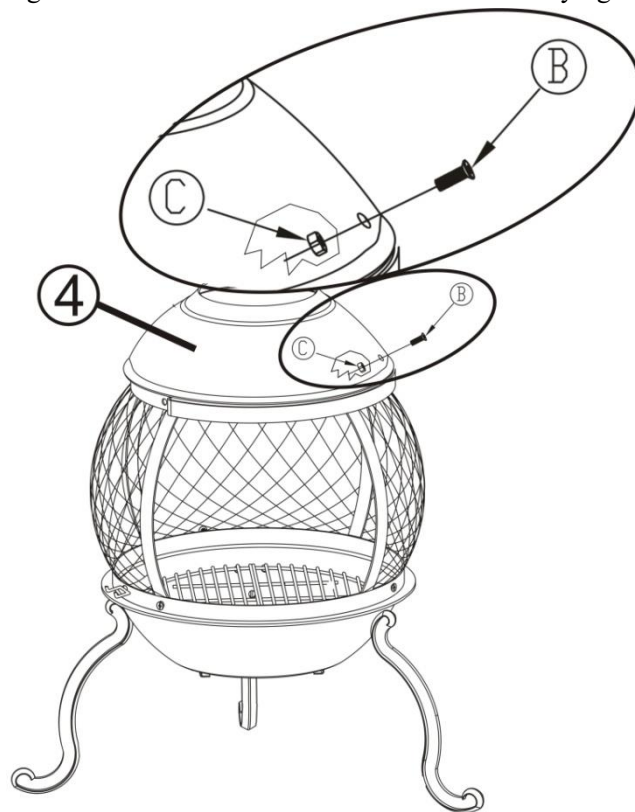

STEP 6

Connect lower flue (3) to stove top (4) using three Bolt M6X25mm and Nuts. Secure all bolts from previous steps, but do not over tighten.

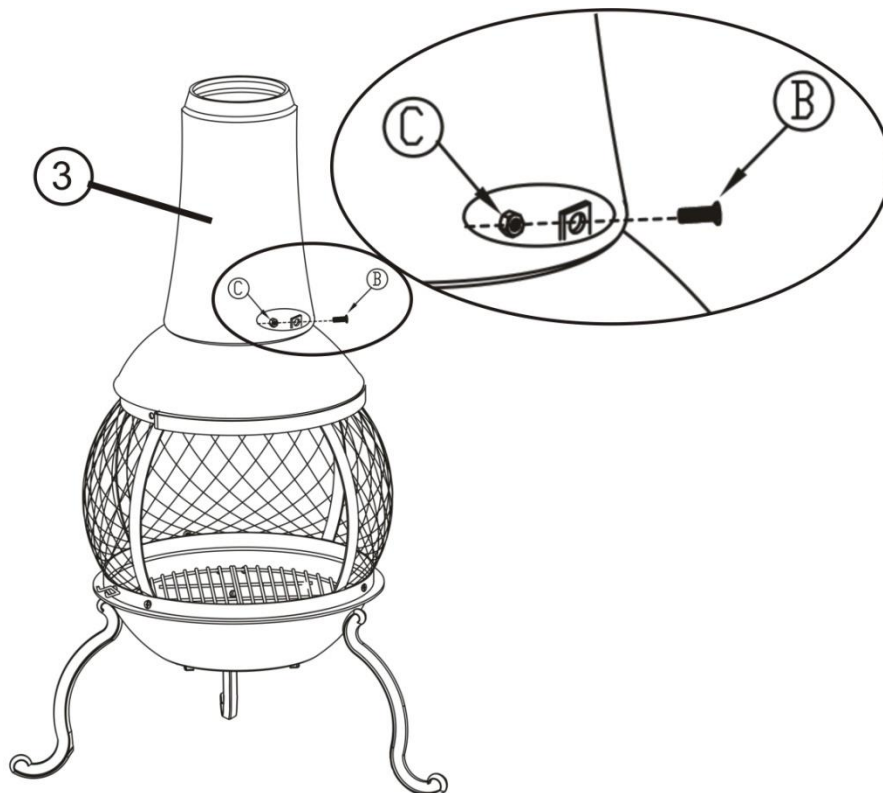

STEP 7

Attach upper flue (2) to lower flue (3) using three Bolt M6X20mm . Tighten securely.

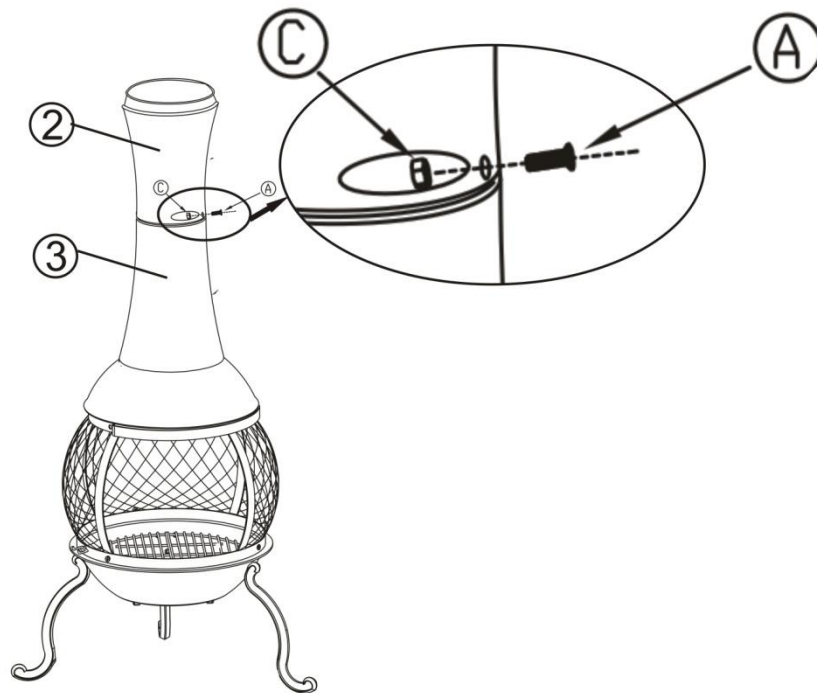

STEP 8

Place Cap(1) and Spark Arrestor Screen(8) into Upper Flue as shown.

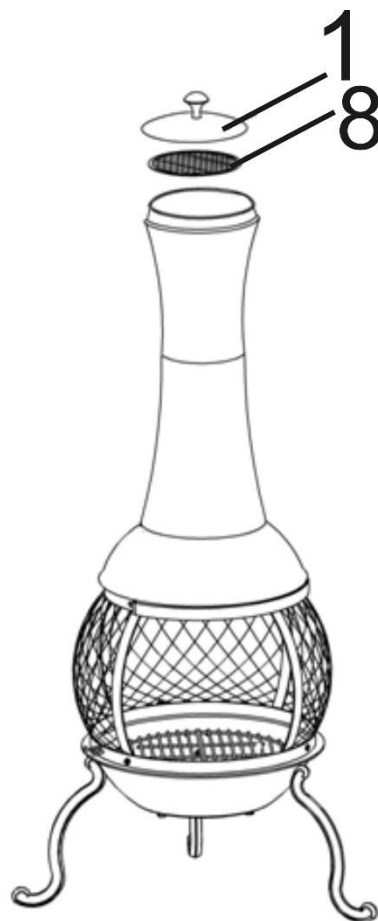

STEP 9

Insert ash tray (14) into stove bottom and put safety tool (11) on the hook, Install the door (13) onto the Mesh stove assembly (5) . Be sure to tighten all loose of the loose screws in steps 1-8.

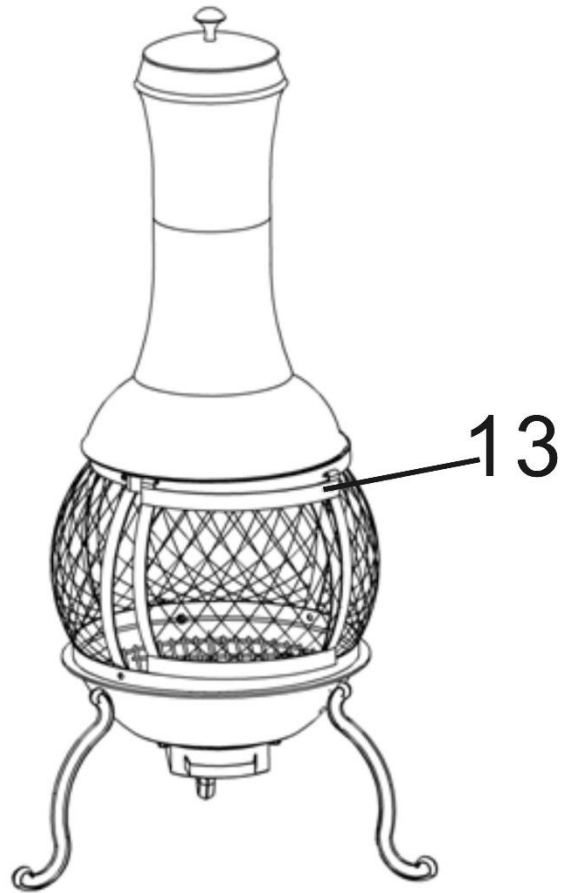

Your Chiminea is now ready for use. Please take care when lighting your Chiminea. Always keep children away from this Chiminea at all times.





Thank you for purchasing one of our quality Jumbuck Chiminea.

YOUR JUMBUCK CHIMINEA IS COVERED AGAINST DEFECTS FOR A PERIOD OF 12 MONTHS FOR PARTS AND LABOUR, REPAIR OR REPLACEMENT

THIS WARRANTY EXCLUDES SURFACE RUST AND DAMAGE CAUSED BY ABUSE OR NEGLIGENCE

CONDITIONS OF THE WARRANTY

- The appliance must be operated and maintained in accordance with the instructions
- supplied in the operating manual.
- Any repair does not extend the warranty period.
- Any parts other than original Jumbuck parts will void this warranty.

FOR WARRANTY CLAIMS

This warranty for Australia is given by :

Genesis Australia Corporation Pty Ltd
1/71 Truganina Road Malaga WA 6090
08 9248 9822

service@genesiscorp.com.au

The warranty for New Zealand is given by Bunnings NZ Ltd, PO Box 14436, Panmure, Auckland, 1741

Tel: 09 9782200 Fax: 09 9782222

Email: Marketing@bunnings.co.nz

Any claim under this warranty must be made within 12 months from the date of purchase of the product. Proof of purchase must be presented.

WARRANTY

For Australian Customers

To make a claim under the warranty please contact service@genesiscorp.com.au or return the product

(with proof of purchase) to any Bunnings store.

(see www.bunnings.com.au for store locations)

Genesis Australia Corporation Pty Ltd bears reasonable, direct expenses of claiming under the warranty. You may submit details and proof to us for consideration. The warranty covers manufacturer defects in materials, workmanship and finish under normal use.

This warranty is provided in addition to other rights and remedies you may have under law: our goods come with guarantees which cannot be excluded under the Australian Consumer Law. You are entitled to a replacement or refund for a major failure and to compensation for other reasonably foreseeable loss or damage. You are also entitled to have the goods repaired or replaced if the goods fail to be of acceptable quality and the failure does not amount to a major failure.

For New Zealand Customer

To make a claim under warranty return to any Bunnings store (see www.bunnings.co.nz for store locations)

Bunnings NZ Ltd bears reasonable, direct, expenses of claiming under the warranty. You may submit details and proof to our store for consideration.

This warranty is provided in addition to other rights and remedies you may have under law : our goods come with guarantees which cannot be excluded under the Consumer Guarantees Act 1993 (NZ). You are entitled to replacement or refund for a major failure and to compensation for other reasonably foreseeable loss or damage. You are also entitled to have the goods repaired or replaced (goods presented for repair may be replaced with refurbished goods of the same type rather than being repaired. Refurbished parts may be used to repair the goods) if the goods fail to be of acceptable quality and the failure does not amount to a major failure.

The warranty excludes damage resulting from product misuse or product neglect. The warranty covers domestic use only and does not apply to commercial applications.

Please thoroughly read conditions of warranty

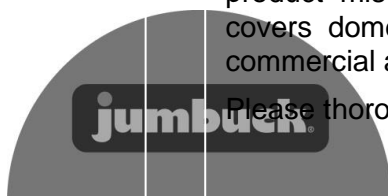



WHAT IS NOT COVERED IN THE WARRANTY

- ⤴ Removal or re-installation costs. This warranty does not cover costs for transit, nor in home service
- ⤴ Liability will only be accepted for loss or damage during transit if at the time the product was being transported by Bunnings or a Bunnings approved contractor.
- ⤴ Lack of maintenance, abuse, neglect, misuse, accidental or improper installation of this appliances
- ⤴ Scratches, dents, corrosion or discoloration caused by heat or abrasive chemicals cleaners.
- ⤴ Corrosions or damage caused by exposure to elements such as insects, weather or hail
- ⤴ Rusting of grill
- ⤴ Cleaning and wear and tear, service calls of this nature are chargeable
- ⤴ Commercial use of this product
- ⤴ Unauthorized repairs or modification during warranty period

FOR TECHNICAL ASSISTANCE

For Australia customers if you experience any technical issues with your JUMBUCK CHIMINEA, in the first instance review the instructions manual or contact the warranty service agent.

For New Zealand customers if you experience any technical issues with your JUMBUCK CHIMINEA, in the first instance review the instructions manual or contact your local Bunnings warehouse

FOR SPARE PARTS

Call your local Bunnings warehouse and ask them to order a part for you. You should provide the following information:

- Model of CHIMINEA.....
- Year of purchase.....
- Name of warranty service company above.....
- Part that requires replacement (refer to the list of spare parts in the instructions manual)

RECORD THE FOLLOWING INFORMATION

Attached the copy of the purchase receipt here

- Date of Purchase.....
- Purchased From.....
- Location.....
- Model Name and Number.....
- Serial Number.....
- Receipt Number.....

